

NOTE:  
TOLERANCE UNLESS SPECIFIED:  $\pm\frac{1}{2}$ " [12.7]

ROOM FINISH:  
WALLS & CEILING: EPOXY WHITE - INTERIOR/EXTERIOR  
FLOORS: CORROSION RESISTANT & ANTI-SLIP

APPROVAL DRAWING	
<input type="checkbox"/> APPROVED	
<input type="checkbox"/> APPROVED AS NOTED	
<input type="checkbox"/> RETURNED FOR CORRECTIONS	
INITIAL: _____	DATE: _____



TITLE PGC 9324 UNIT & DUCT SYS. PLAN VIEW (8'x8')	
DATE 13 Dec 2022	DRAWN JP/HL
REV. A	DWG. NO. 22120817
SHEET 1 of 5	

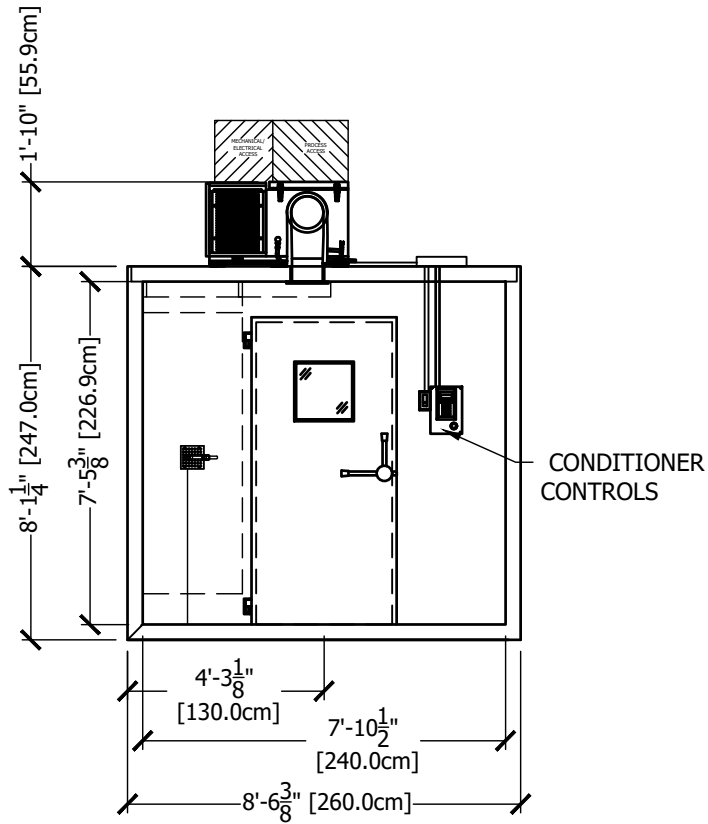

**ROOM FINISH:**  
 WALLS & CEILING: EPOXY WHITE - INTERIOR/EXTERIOR  
 FLOORS: CORROSION RESISTANT & ANTI-SLIP

NOTE:  
 TOLERANCE UNLESS SPECIFIED:  $\pm\frac{1}{2}$ " [12.7]

<b>APPROVAL DRAWING</b>	
<input type="checkbox"/> APPROVED <input type="checkbox"/> APPROVED AS NOTED <input type="checkbox"/> RETURNED FOR CORRECTIONS	
INITIAL: _____	DATE: _____



TITLE		PGC 9324 UNIT & DUCT SYS. FRONT ELEVATION (8'x8')	
DATE	13 Dec 2022	DRAWN	JP/HL
REV.	DWG. NO.	SHEET	
A	22120817	2 of 5	

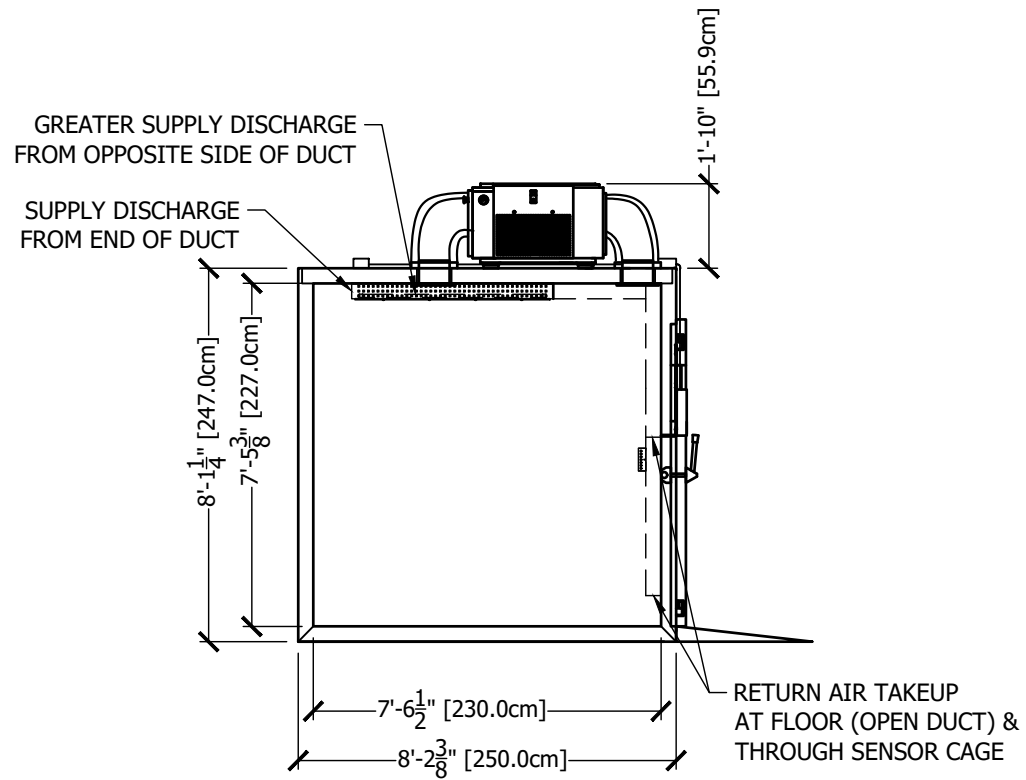

**ROOM FINISH:**  
 WALLS & CEILING: EPOXY WHITE - INTERIOR/EXTERIOR  
 FLOORS: CORROSION RESISTANT & ANTI-SLIP

NOTE:  
 TOLERANCE UNLESS SPECIFIED:  $\pm \frac{1}{2}$ " [12.7]

<b>APPROVAL DRAWING</b>	
<input type="checkbox"/> APPROVED <input type="checkbox"/> APPROVED AS NOTED <input type="checkbox"/> RETURNED FOR CORRECTIONS	
INITIAL: _____	DATE: _____

 <b>PARAMETER</b> GENERATION & CONTROL Black Mountain, NC	TITLE PGC 9324 UNIT & DUCT SYS. LEFT ELEVATION (8'x8')	
	DATE 13 Dec 2022	DRAWN JP/HL
REV. <b>A</b>	DWG. NO. 22120817	SHEET 3 of 5

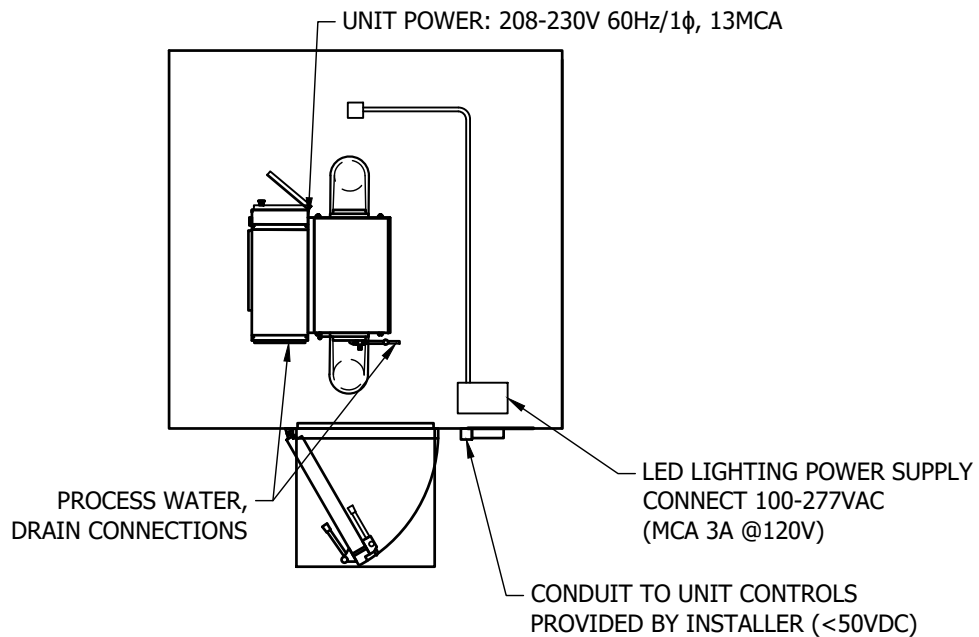

NOTE:  
TOLERANCE UNLESS SPECIFIED: ±½" [12.7]

<b>APPROVAL DRAWING</b>	
<input type="checkbox"/> APPROVED <input type="checkbox"/> APPROVED AS NOTED <input type="checkbox"/> RETURNED FOR CORRECTIONS	
INITIAL: _____	DATE: _____



TITLE PGC 9324 UNIT & DUCT SYS. UTILITIES (8'x8')		
DATE 13 Dec 2022	DRAWN JP/HL	
REV. A	DWG. NO. 22120817	SHEET 4 of 5

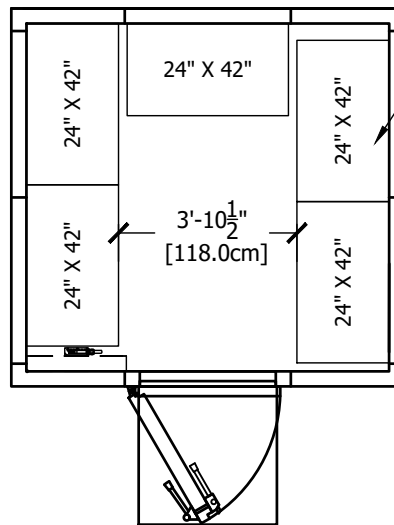

17.5 LINEAR FT SHELVING;  
35 FT<sup>2</sup> PER TIER

NOTE:  
TOLERANCE UNLESS SPECIFIED:  $\pm\frac{1}{2}$ " [12.7]

<b>APPROVAL DRAWING</b>	
<input type="checkbox"/> APPROVED <input type="checkbox"/> APPROVED AS NOTED <input type="checkbox"/> RETURNED FOR CORRECTIONS	
INITIAL: _____	DATE: _____



TITLE PGC 9324 UNIT & DUCT SYS. SHELVING PLAN (8'x8')		
DATE 13 Dec 2022	DRAWN JP/HL	
REV. A	DWG. NO. 22120817	SHEET 5 of 5